



EXAG – Profinet Removable End Cap

- Shaft Encoder – Ø78 mm
- Shaft: Ø10 mm, Ø12 mm
- Profinet
- Resolution up to 30 bits
- Removable End Cap for on-site modification
- ATEX, IECEx, EAC Ex and North America Class I Div. 2, Ex db IIC



Electrical Specifications	
Code:	Absolute - Binary
Interface:	Profinet
Profile	Profidrive Profile 4.x, Encoder Profile 4.x
Resolution:	Max. 14 bit (16384) revolutions Max. 16 bit (65536) steps per rev.
Device Addressing:	Programmable IP address and Network parameters
Transmission Rate:	10/100 Mbit
Supply Voltage:	10 to 30 Vdc (absolute limits)
Current Consumption:	Max. 230 mA with 10 Vdc Max. 100 mA with 24 Vdc
Power Consumption:	Max. 2.5 watts
Accuracy (INL):	±0.0220° (14-16 bit), ±0.0439° (≤13 bit)
MTTF:	65 years @ 40°C
Electrical Protection:	Reverse polarity and over-voltage-peak protection
Noise Immunity:	EN61000-6-2
Emitted Interference:	EN 61000-6-4

Mechanical Specifications	
Material:	Housing: Aluminum or Stainless Steel Cap: Aluminum or Stainless Steel Shaft: Stainless Steel
Weight:	Aluminum: ~ 1600 gr (56,44 oz) Stainless Steel: ~ 3100 gr (109,35 oz)
Bearing Life:	> 1,9 x 10 ¹⁰ revolutions at rated load
Shaft Speed:	6.000 rpm (max.) IP 64 3.000 rpm (max.) IP 65, IP 66, IP 67
Starting Torque:	≤ 0,01 Nm at 25° C (no seal) ≤ 0,03 Nm at 25° C (with seal)
Rotor Mass Moment of Inertia:	42 gcm ² (5,95 x 10 ⁻⁴ oz-in-sec ²)
Shaft Loads:	Axial: 60 N (13,50 lbs) max. Radial: 80 N (17,98 lbs) max.

Environmental Specifications	
Operating Temp.:	-40° to +70° C
Storage Temp.:	-40° to +70° C
Shock:	100g @ 11 ms
Vibration:	10g @ 10-2000 Hz
Bump:	10g @ 16 ms (1000 x 3 axis)
Humidity:	98 % RH without condensation
Enclosure Rating:	IP 64 / Nema 4 (approx.) IP 65 / Nema 5 (approx.) IP 66 / Nema 6 (approx.) IP 67 / Nema 6 (approx.) IP 68 (1hour/1 meter) / Nema 6P (approx.)

Certifications

ATEX:	Certificate No.: ITS09ATEX16867X II 2 G Ex db IIC T5 Gb II 2 D Ex tb IIIC T100°C Db -40°C ≤ Ta ≤ +70°C
IECEX:	Certificate No.: IECEX ITS 10.0016X Ex db IIC T5 Gb, Ex tb IIIC T100°C Db -40°C ≤ Ta ≤ +70°C
North America:	Certificate No: LR1192-5 Class I Division 2 Groups ABCD T5, Class II Division 2 Groups FG, Class I Zone 1AEx db IIC T5 Gb, Ex db IIC T5 Gb, Zone 21 AEx tb IIIC T100°C Db, Ex tb IIIC T100°C Db, Tamb= -40 °C to +70 °C
EAC Ex:	HAHIO «ИСБЭ» No. EAЭC RU C-DK.AA87.B.00266/19 1Ex db IIC T5 Gb X, Ex tb IIIC T100°C Db X -40°C < T.amb < +70°C

Interface

PROFINET technology

PROFINET is an Industrial Ethernet standard merging plant automation with other enterprise IT resources.

It provides comparable functionality to PROFIBUS with techniques used by engineering, IT, and management personnel.

Established IT standards are employed as basis of communication: TCP, UDP, IP. XML is used as description language for device profiles (GSDML files).

Two ways of using PROFINET are available: PROFINET IO, similar to PROFIBUS DP as a distributed I/O system and PROFINET CBA as a modular component-based system for larger systems.

PROFINET offers scalable communication for different applications in industrial automation:

- PROFINET NRT (non real time) is suited for non-time-critical process automation with clock rates of roughly 100 msec.
- PROFINET RT (real time) offers a communication channel with optimized performance (10 msec clock rate) for most factory automation tasks
- PROFINET IRT (isochronous real time) employs special communication hardware to enable clock rates of less than 1 msec and a jitter precision of less than 1 µsec. This channel is mainly of use for motion control applications.

PROFINET IO uses a view of distributed I/O similar to PROFIBUS DP. IO controllers (e.g. PLCs) run an automation program, IO devices (e.g. absolute encoders) are remotely assigned field devices, and IO supervisors (e.g. programming devices) are used for commissioning and diagnostics.

The engineering of PROFINET IO is done similar to PROFIBUS. The field buses (i.e. Ethernet topologies) are assigned to control systems during configuration. The IO device is configured in the actual system based on the contents of its GSDML file.

After completion of the engineering the installer loads the data for the expansion into the IO controller (PLC) and the IO controller assumes data exchange with the IO device.

An IO device is addressed within PROFINET (and also possibly by external IT components) through its IP address.

Data can be exchanged from the IO controller to the IO device (and vice versa) cyclically (for process data). Apart from this, parameter data can be exchanged acyclically during engineering of the IO device or by the use of PLC programming blocks.

The GSDML file is necessary for installing the encoder. The **GSDML file can be downloaded [here](#)**

Output Terminations

Terminal connections

Position	Terminal
1	GND
2	Vsup
3	N.C.
4	N.C.
5	Rx -
6	Tx -
7	Rx +
8	Tx +

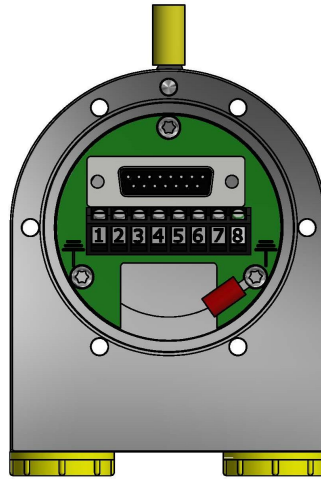

Internal earth connection
 (red cable shoes) is 22-16 AWG.
La connexion à la terre interne
 (Borne rouge) est en 22-16 AWG.

External earth connection
 (yellow cable shoe) is 12-10 AWG.
La connexion de terre externe
 (Borne jaune) est en 12-10 AWG.

Wire conductor size AWG 22-12,
 0.14 mm² – 2.5 mm².
La taille de fil nominale est AWG 22-12,
 0.14 mm² – 2.5 mm²

Face Mounts

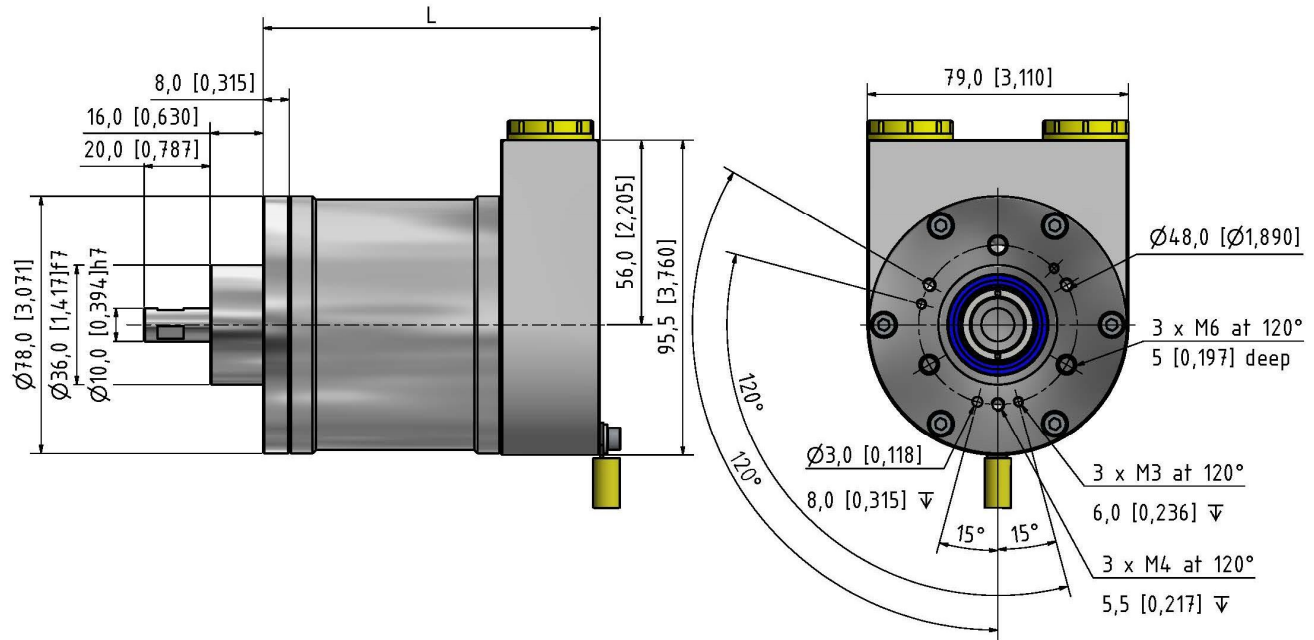

Face Mount C
 Clamping Flange

mm [inches]

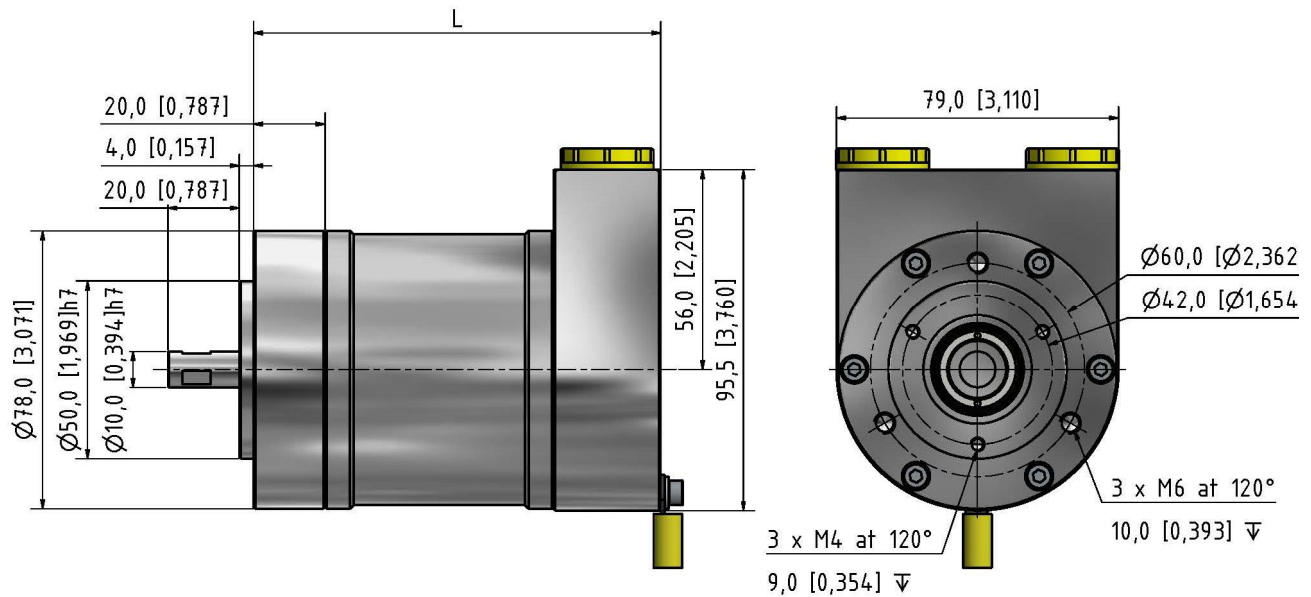

Face Mount S
Servo Flange

mm [inches]

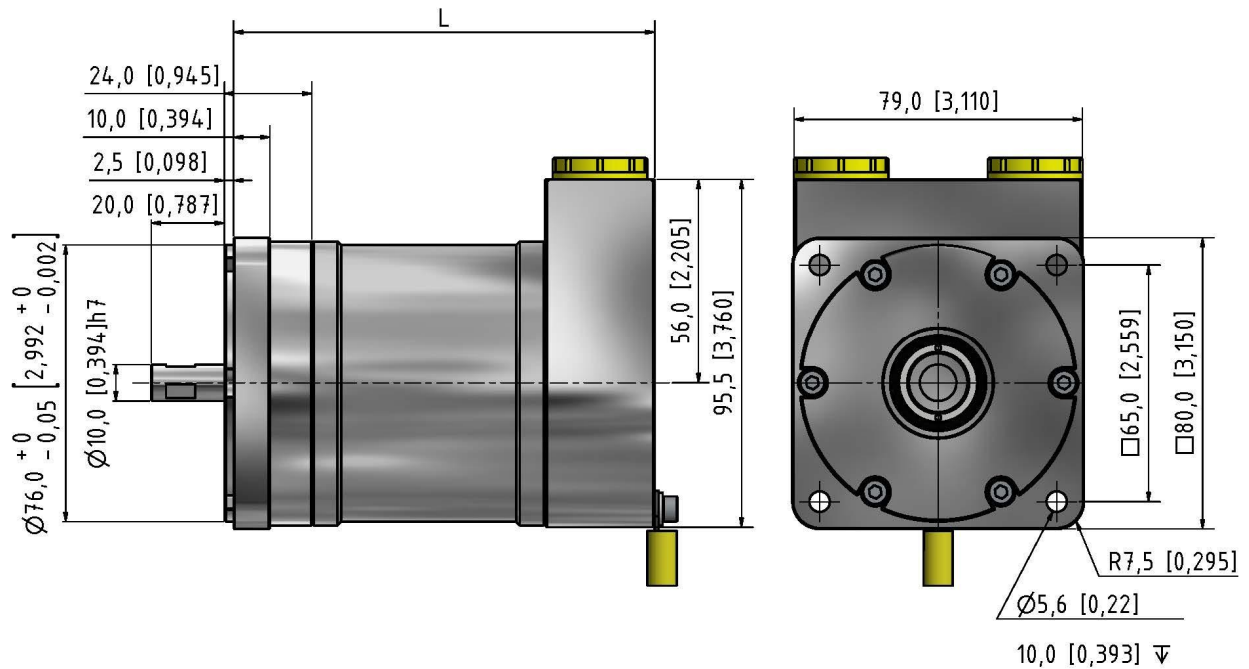

Face Mount Q
Square Flange

mm [inches]

VA/SA option only

End Caps with Cable Outlets

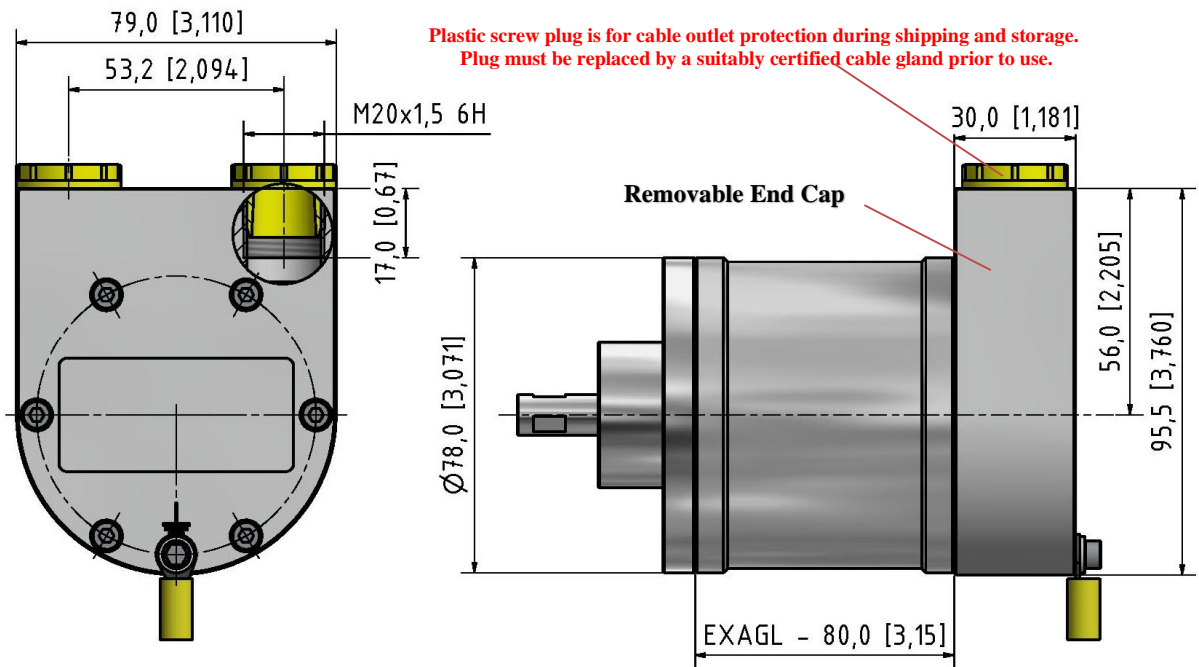

Side Standard End Cap (FZ)

mm [inches]

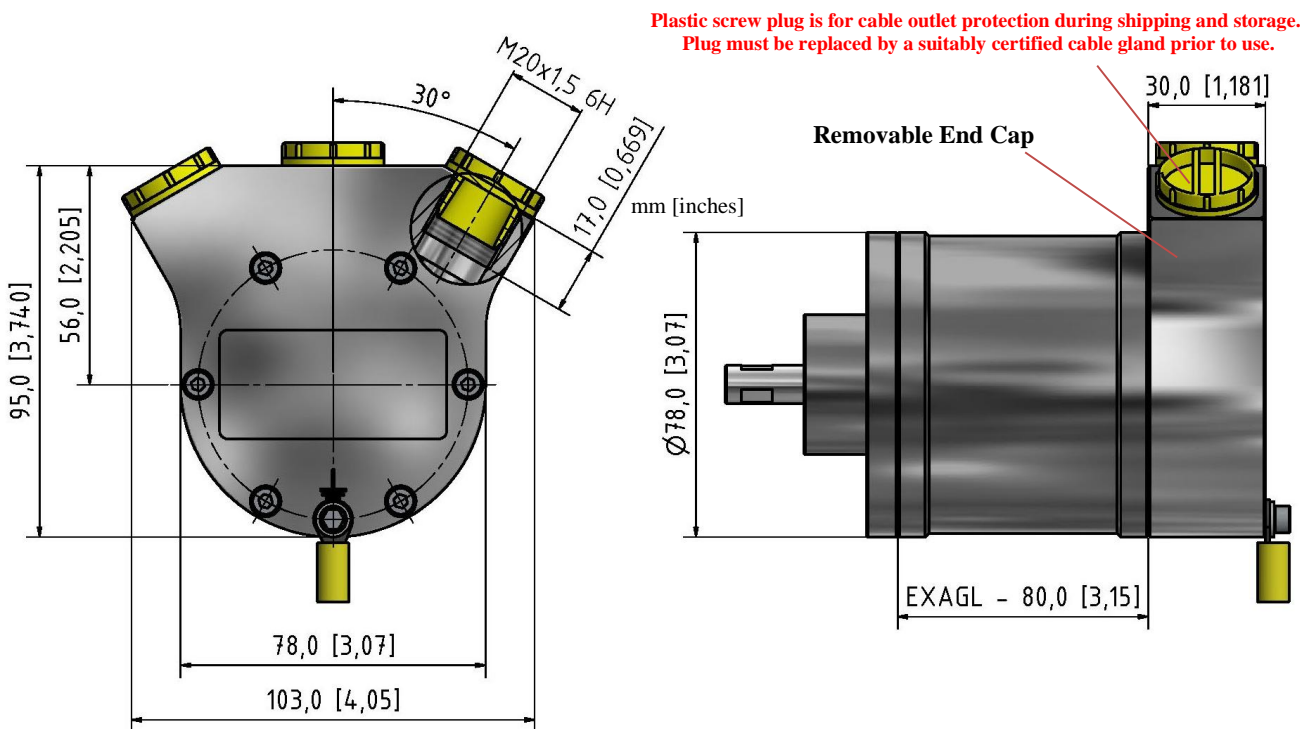

Side Standard End Cap (FE)

mm [inches]

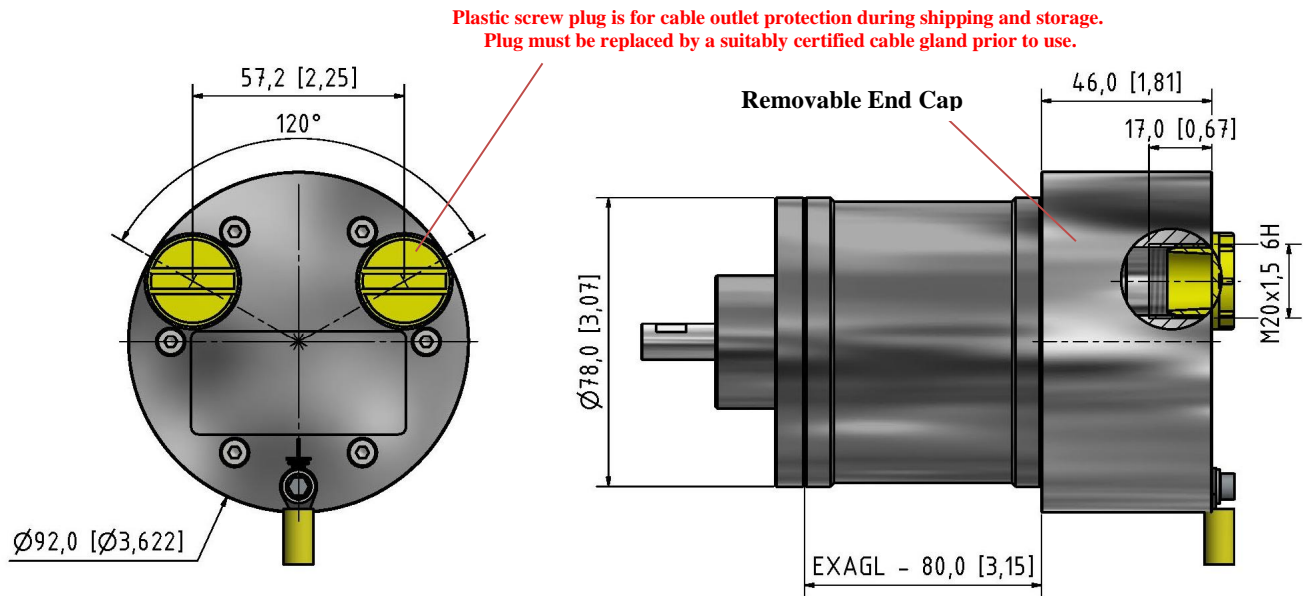

Back Standard End Cap (FG)

mm [inches]

Encoder Length

Housing L (Table 1) (80 mm)

Total Encoder Length

End Cap	Face Mount		
	Clamping Flange C	Servo Flange S	Square Flange Q
FZ	118 mm (4,645 in)	130 mm (5,118 in)	131,5 mm (5,177 in)
FE	118 mm (4,645 in)	130 mm (5,118 in)	131,5 mm (5,177 in)
FG	134 mm (5,275 in)	146 mm (5,748 in)	147,5 mm (5,807 in)

End Cap + Face Mount + 80 mm = Total Encoder Length

Ordering Code

Example: EXAGL - EIZ1B - 12 - 16 - A - AL - 01 - 66 - 00 - FZ - C - 00

EXAG	L	-	EIZ1	B	-		-		-	A	-		-		-	00	-		-		-	00
1			2			3		4		5		6		7		8		9		10		11

1. Housing

80 mm length **L**

See Table 1

2. Interface

Vers. **EIZ1**
Code Binary **B**

3. Revolutions

Single Turn **00**
Multiturn 12 bits (4096) **12**
Multiturn 14 bits (16384) **14**

4. Steps per revolution

13 bits (8192) (0.04°) **13**
16 bits (65536) (0.005°) **16**

5. Composition

Aluminum **AL**
Stainless Steel* **VA**
Stainless Steel** **SA**

* *AISI 303*
** *AISI 316*

6. Shaft (diameter x length)

10 mm x 20 mm 2 flats, 8mm length **01**
12 mm x 25 mm 2 flats, 8 mm length **02**
10 mm x 20 mm 1 flat, 15 mm length ... **03**

7. IP Rating

IP 64 **64**
IP 65 **65**
IP 66 **66**
IP 67 **67**
IP 68* **68**

*1 meter/1 hour

8. Cable

No cable **00**

9. Cable Outlets

Side Standard 2 outlets **FZ**
Side Triple 3 outlets **FE**
Back Round 2 outlets **FG**

10. Flange

Clamping flange **C**
Synchro flange **S**
Square VA/SA option only **Q**

11. Accessory

No accessory **00**